

# XIBU touchMULTIFOLD – ORDERING INFORMATION

**XIBU touchMULTIFOLD:** Multifold handtowel dispenser with synthetic case in XIBU design.  
User friendly paper removal, lockable, one-hand lid opening, visual filling level indication.

## Refills:

**TAKE 1 handTOWEL R1** 3,000 pcs./carton, Art.-No. 4111000100  
Recycling tissue, especially soft, Z-fold, 1 ply, tear resistant.



**TAKE 1 handTOWEL W2** 3,000 pcs./carton, Art.-No. 4111000400  
Bright white, Z-fold, 2-ply, tear resistant.

**paperTOWEL R1** 3,840 pcs./carton, Art.-No. 4111000300  
Recycling tissue, especially soft, highly absorbing, C-fold, 1 ply, tear resistant.

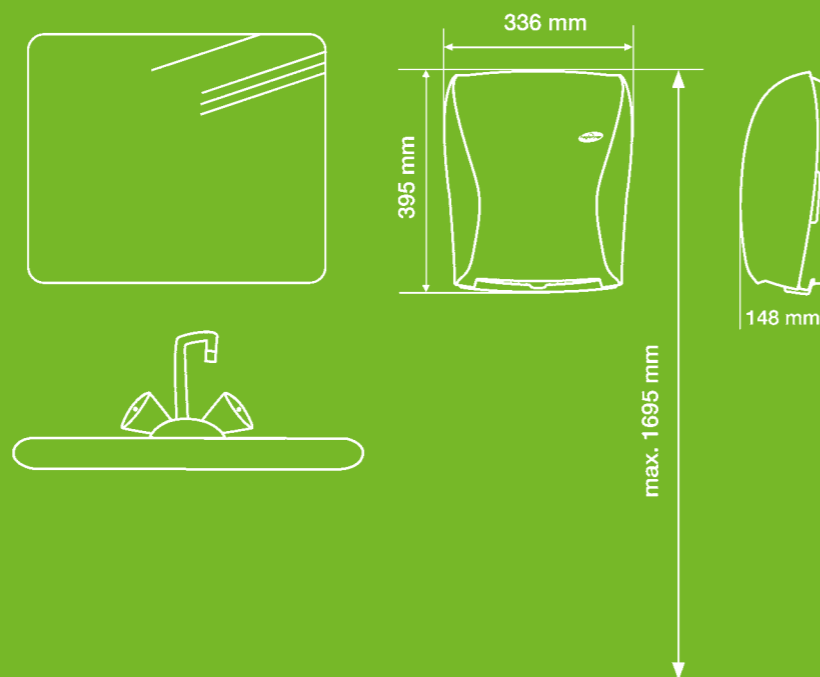

[www.hagleitner.com](http://www.hagleitner.com)

HAGLEITNER HYGIENE  
INTERNATIONAL GmbH  
Lunastrasse 5  
5700 Zell am See  
Austria  
phone +43 (0)5 0456  
fax +43 (0)5 0456 90111  
[international@hagleitner.com](mailto:international@hagleitner.com)

Dispenser „designed by STORZ“ Art.-No. 20701282

# touch MULTIFOLD

the new washroom generation

# Xibu

*intelligent balanced unique*



For information, visit [www.hagleitner.com](http://www.hagleitner.com)

eng

# XIBU touchMULTIFOLD – YOUR BENEFITS

## Heavy-duty housing

The high quality synthetic case is immune to kicks and scratches. The dispenser surface is easy to clean.

## Simple cover opening

Only one hand is necessary to release the lid. The dispenser lid opens automatically and swings mechanically to the top.

## Optical fill level display

Without opening the dispenser, you can see with the help of the filling level indication, when the paper is running low.

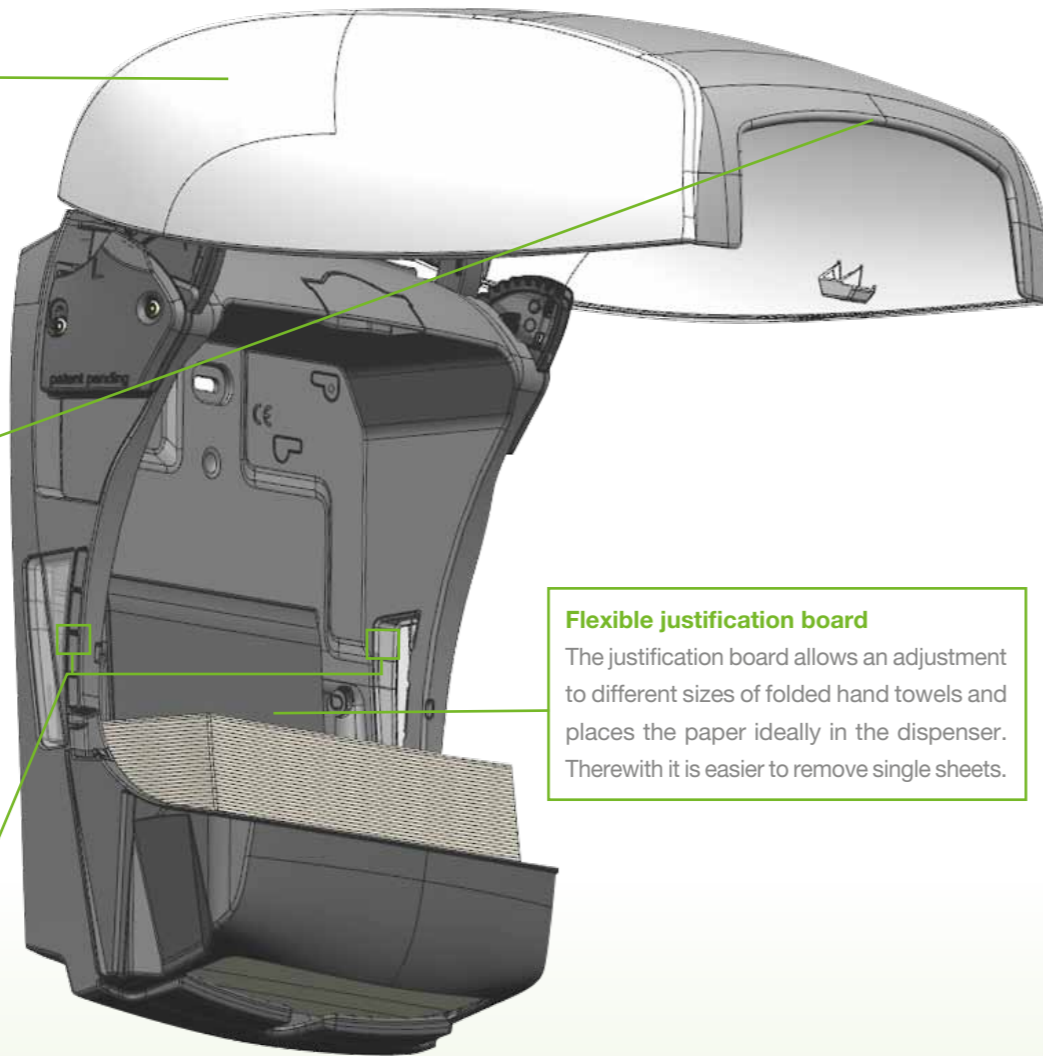

## Flexible justification board

The justification board allows an adjustment to different sizes of folded hand towels and places the paper ideally in the dispenser. Therewith it is easier to remove single sheets.

## User friendly operation

The lid release from the bottom enables a flexible wall fastening. The system key secures your refill from theft.

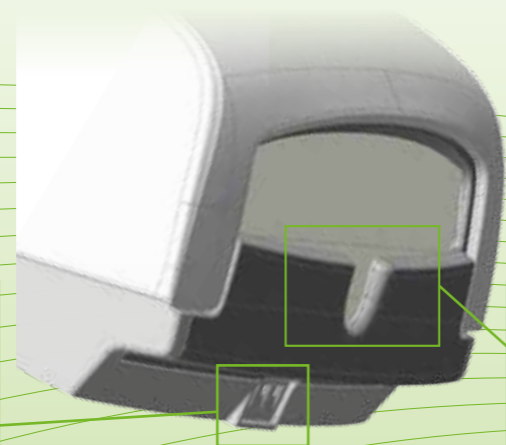

## Optimised removal opening

The improved removal opening makes the single-sheet removal easy. It avoids that more papertowels fall through.

# THE INTELLIGENT MULTIFOLD DISPENSER



The multifold dispenser **XIBU touchMULTIFOLD** offers hygienic solutions for each washroom. This compact dispenser made of high quality synthetic convinces through functionality and design.

## intelligent

The service for the **XIBU touchMULTIFOLD** is easy. With the vision panel on the left and right hand side of the dispenser you can see the filling level with one view. The lid can be released effortlessly with one hand using the system key. The big lid opening ensures an easy and smooth refill of the dispenser.

## balanced

The slim dispenser case offers plenty of space for all common multifoldsizes- and qualities. Completely filled it offers space for more than 400 folded papertowels. A flexible board inside the dispenser optimizes the removal for each paper size. That and the ergonomic removal opening make it easy to take single sheets and as a result the paper consumption drops.

## unique

Technic finesse like the removal opening, justification board and filling level indication combined with modern design in classic white make the **XIBU touchMULTIFOLD** an unique dispenser, which fits perfectly in the **XIBU** washroom system.

**Innovative technology and unique design  
– that's what the XIBU washroom system stands for.**

